



The best just got better

MODEL T-2175

TOWER SPECIFICATIONS



Cooling Tower Systems, Inc.

196 Lower Cherry Street Macon, GA 31201

TF: 800.752.1905

F: 478.755.8304

www.coolingtowersystems.com

info@coolingtowersystems.com



TOWER SPECIFICATIONS: MODEL T-2175 Cooling Tower Systems, Inc.

Design and Operating Conditions		Water Distribution System Construction Materials	
Tower Type:	Counter Flow Induced Draft	Stand Pipe:	PVC
Water Flow Rate (GPM):	518 GPM	Sprinkler Head:	AC
Entering Water Temperature	95°F	Sprinkler Pipes:	PVC
Leaving Water Temperature	85°F	Mechanical Equipment	
Wet Bulb Temperature:	75°F	Fan Unit:	One Unit per Tower
Total Fan BHP:	5 HP	Type:	Axial Flow
Total Pump Head:	11'	Manufacturer:	CTS
Drift Loss of Water Flow:	0.1%	Diameter:	68 7/8"
Evaporation Loss of Water Flow:	0.93%	Blade Material:	AC
Design Wind Load:	41 lbs/sq. ft.	Hub Material:	AC
Structural Details		Nominal Air Volume:	40,250 CFM
Overall Diameter:	130"	Fan Motor	
Overall Height:	97 7/8"	Number of motors:	One Unit per Tower
Dry Weight:	1,571 lbs.	Type:	Induction
Operating Weight:	6,375 lbs.	Manufacturer:	CTS
Basic Tower Construction Materials		Insulation:	F Class
Tower Support Frame Assembly	HDGS	Rated HP:	5 HP
Casing:	FRP	Voltage and phase:	220/440V/3
Casing Supporters	HDGS	Piping Connections	
Cold Water Basin	FRP	Primary Water Inlet Diameter	6"
Filling:	PVC	Primary Water Outlet Diameter:	6"
Filling Supports:	HDGS	Auto fill inlet diameter:	1"
Fan Guard	HDGS	Quick fill inlet diameter:	-
Mechanical Equipment Supports:	HDGS	Overflow outlet diameter:	2"
Inlet Louvers:	PVC	Drain diameter:	1"
Bolts, Nuts & Washers:	STS	Water Flow (GPM):	518 GPM
Materials Key			
FRP	Fiberglass Reinforced Polyester	STS	Stainless Steel
HDGS	Hot Dipped Galvanized Steel	AC	Aluminum Alloy Cast

Cooling Tower Systems, Inc.

196 Lower Cherry Street Macon, GA 31201

TF: 800.752.1905

F: 478.755.8304

www.coolingtowersystems.com

info@coolingtowersystems.com

PARTS LIST: MODEL T-2175

FOR ASSEMBLY DIAGRAM		
Ref. No.	Description	QTY
01-02	Ring Frame	4
01-05	Truss Pipe Assembly	4
02-01	Water Sump	1
02-02	Outlet Nozzle	1
02-03	Inlet Nozzle	1
02-04	Over Flow Nozzle	1
02-05	Drain Nozzle	1
02-06	Automatic Filler Nozzle	1
02-08	Float Valve Assembly	1
02-09	Over Flow	1
02-10	Suction Strainer	1
02-12A	Connector Pipe	1
02-16	Elbow	1
03-01	Water Basin	6
04-00	Casing Supporter	6
05-01A	Casing	6
05-06	Hand Hole Cover	1
06-01	Stand Pipe	1
06-02	Stand Pipe Base	1
06-03	Packing	1
07-02	Column	1
08-01	Filling Supporter - A	6
08-02	Filling Supporter - B	6
08-03	Filling Supporter - C	12
08-04	Fill Supt. Clamping Band	12
10-01	Ladder (A Section)	1
10-02	Ladder (B Section)	1
10-03	Ladder Bracket - A	2
10-04	Ladder Bracket - B	2
11-01	Filling (Inner Section)	-
11-04	Filling (1/4 Section)	8
11-06	Filling (1/6 Section)	-
12-01	Sprinkler Head	1
12-02	Center Post	1
12-03	Turnbuckle	4
12-04	Tension Wire	4
13-02	End Cap	4
13-03	Eliminator	4
14-01	Frame Ass'y Main Pipe	2
14-02	Frame Ass'y Main Pipe	-
15-01	Motor Base	1
15-02	U-Bolt	-
16-01	Motor	1
16-00	Motor Base Plate	1
16-03	Fan Key	1
16-04	Fasten Nut	1
16-05	Lock Nut	-
17-01	Fan Hub	1
17-02	Fan Blade	1
17-04	U-Bolt	-
18-01	Fan Guard	1

20-02	Inlet Louver	12
20-01A	Louver Support	12
20-01B	Down plug	12
20-01C	Up Plug	12
20-08	Wing Bolt	24
20-09	Plastic Washer	24
OTHERS	Bolts & Nuts	1 SET

FOR TECHNICAL DIAGRAMS			
Item	Description	Material	QTY
1	Fan Motor	-	1 pcs
2	V-Belt Reducer	-	-
3	Motor Frame Assembly	HDGS	1 set
4	Fan Blade Assembly	AC	1 set
5	Fan Guard	HDGS	1 set
6	Casing	FRP	6 pcs
7	Hand Hole	EVA	1 pcs
8	Sprinkler Head	Nylon	1 set
9	Sprinkler Pipes	PVC	4 pcs
10	Eliminator	PVC	4 pcs
11	Tension Device	-	-
12	Stand Pipe	PVC	1 set
13	Filling	PVC	1 set
14	Stopper or Column	AC	1 set
15	Filling Supporter	HDGS	1 set
16	Casing Supporter	HDGS	6 pcs
17	Inlet Louver	PVC	1 set
18	Frame Assembly	-	-
19	Water Basin	FRP	5 pcs
20	Water Sump	FRP	1 pcs
21	Ladder	HDGS	1 set
22	Strainer	PE	1 pcs
23	Flange	HDGS	2 pcs
24	Basin Supporter	-	-

Materials Key	
FRP	Fiberglass Reinforced Polyester
HDGS	Hot Dipped Galvanized Steel
STS	Stainless Steel
AC	Aluminum Alloy Cast
Water Basin Sealing Material	
Fiberglass	1 Set—A
Polyester Resin	1 Keg—B
Catalyst	1 Bottle—C

Cooling Tower Systems, Inc.

196 Lower Cherry Street Macon, GA 31201

TF: 800.752.1905

F: 478.755.8304

www.coolingtowersystems.com

info@coolingtowersystems.com



ASSEMBLY DIAGRAM: MODEL T-2175

Cooling Tower Systems, Inc.

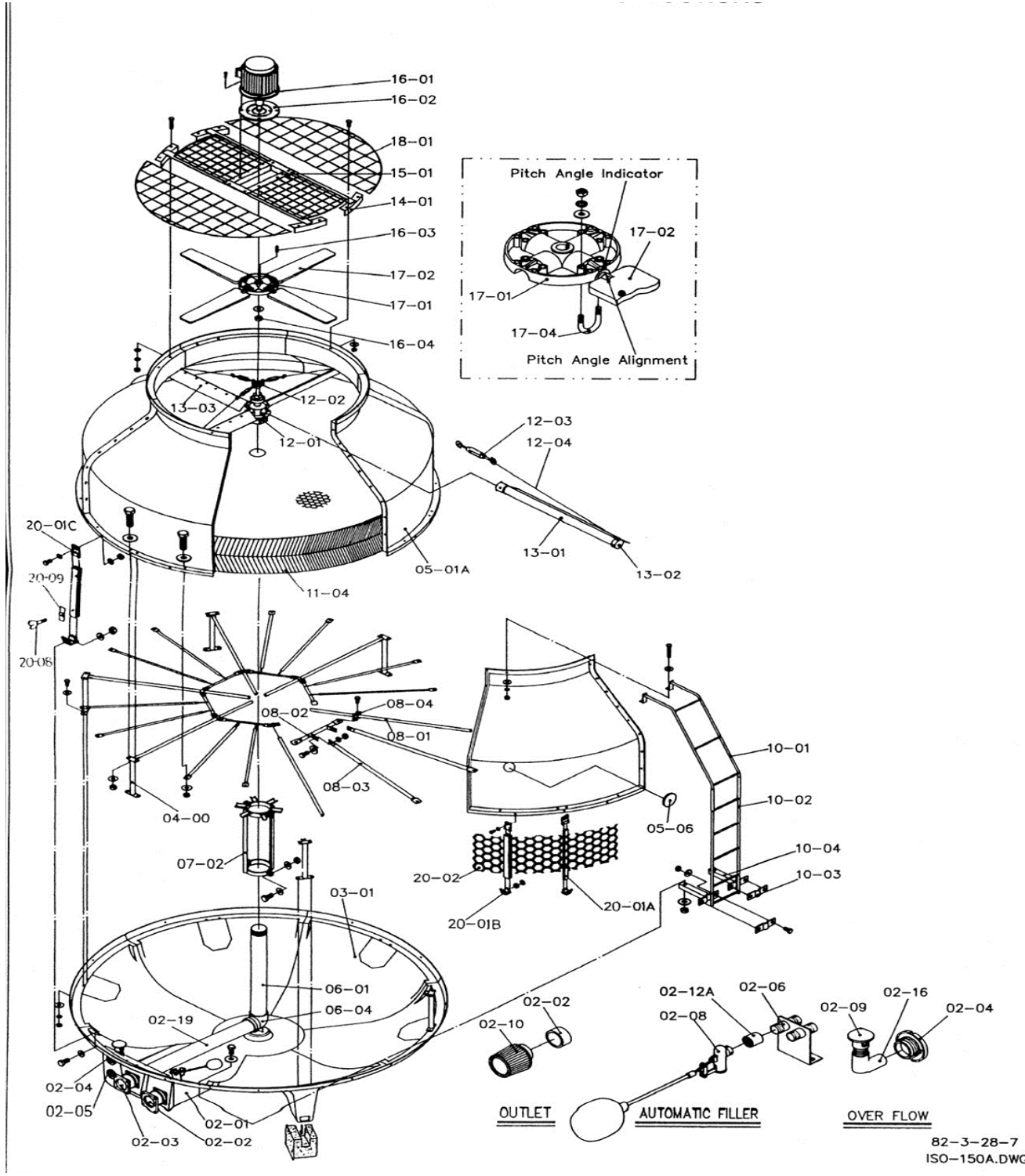

82-3-28-7
ISO-150A.DWG

Cooling Tower Systems, Inc.

196 Lower Cherry Street Macon, GA 31201

TF: 800.752.1905

F: 478.755.8304

www.coolingtowersystems.com

info@coolingtowersystems.com



TECHNICAL IMAGE A: MODEL T-2175

Cooling Tower Systems, Inc.

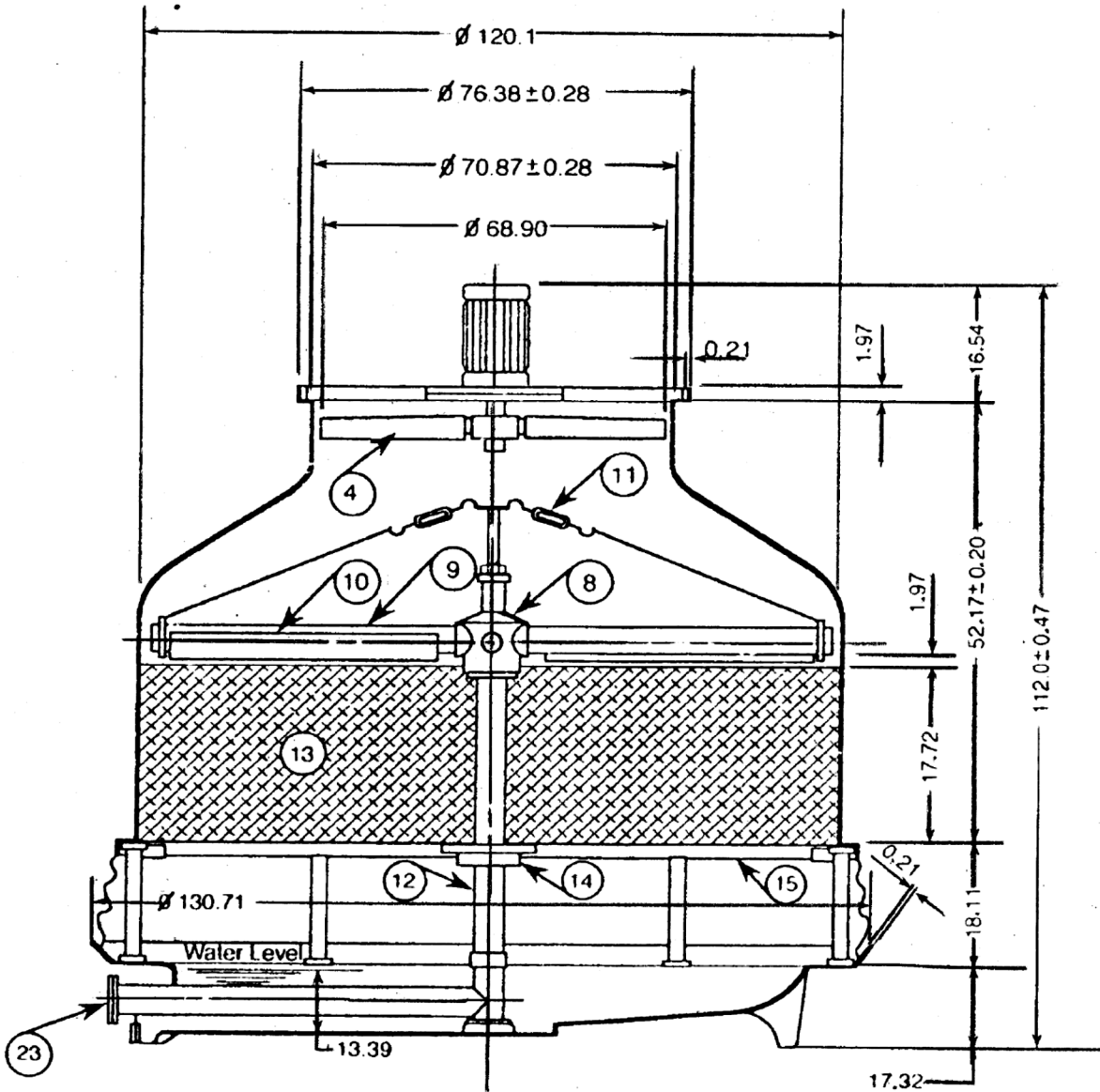

Cooling Tower Systems, Inc.

196 Lower Cherry Street Macon, GA 31201

TF: 800.752.1905

F: 478.755.8304

www.coolingtowersystems.com

info@coolingtowersystems.com

TECHNICAL IMAGE B & C: MODEL T-

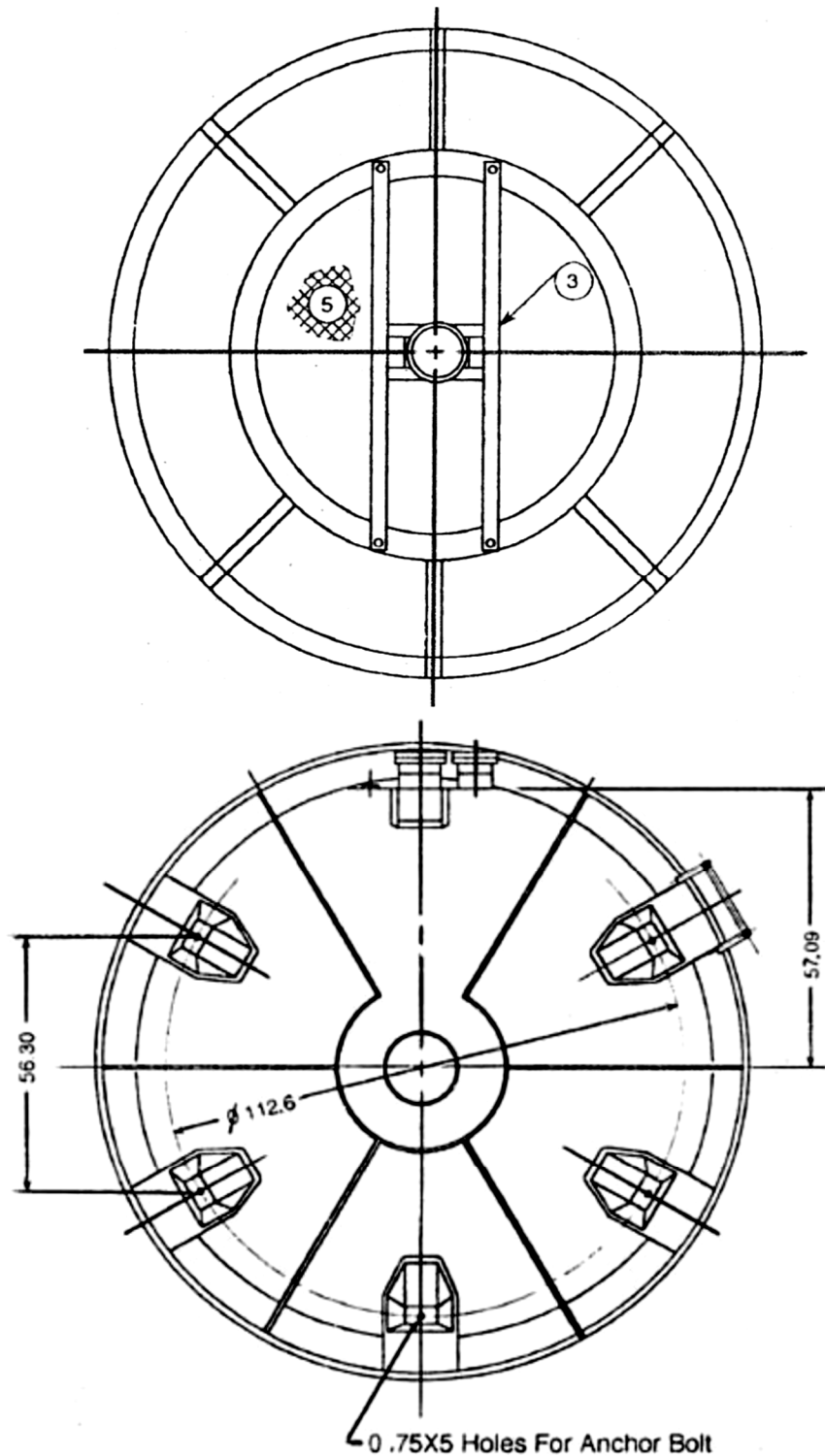

Cooling Tower Systems, Inc.

196 Lower Cherry Street Macon, GA 31201

TF: 800.752.1905

F: 478.755.8304

www.coolingtowersystems.com

info@coolingtowersystems.com



FOUNDATION DRAWING: MODEL T-2175 Cooling Tower Systems, Inc.

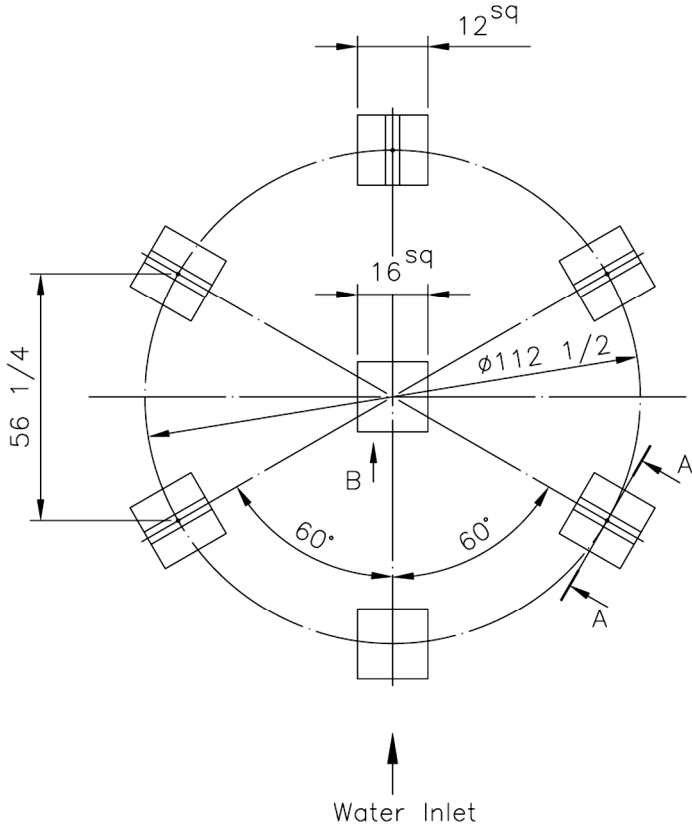

On all tower models T-270 and above, please pay close attention to recommended support foundation for center of cooling tower and outward area where inlet/outlet fittings of cooling tower exist

1 1/2L ALL THREAD PROJECTION
W5/8x8L, L TYPE ANCHOR BOLT 5PCS

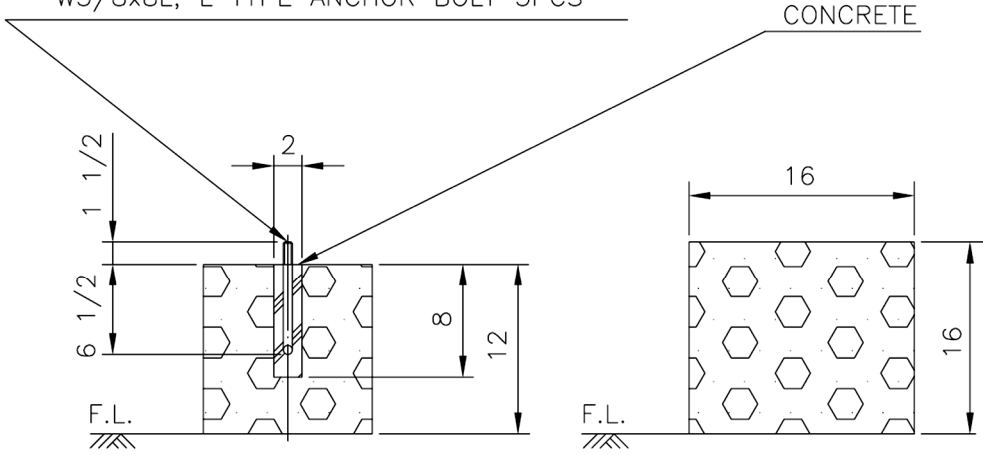

A-A SECTION

B VIEW

Cooling Tower Systems, Inc.

196 Lower Cherry Street Macon, GA 31201

TF: 800.752.1905

F: 478.755.8304

www.coolingtowersystems.com

info@coolingtowersystems.com

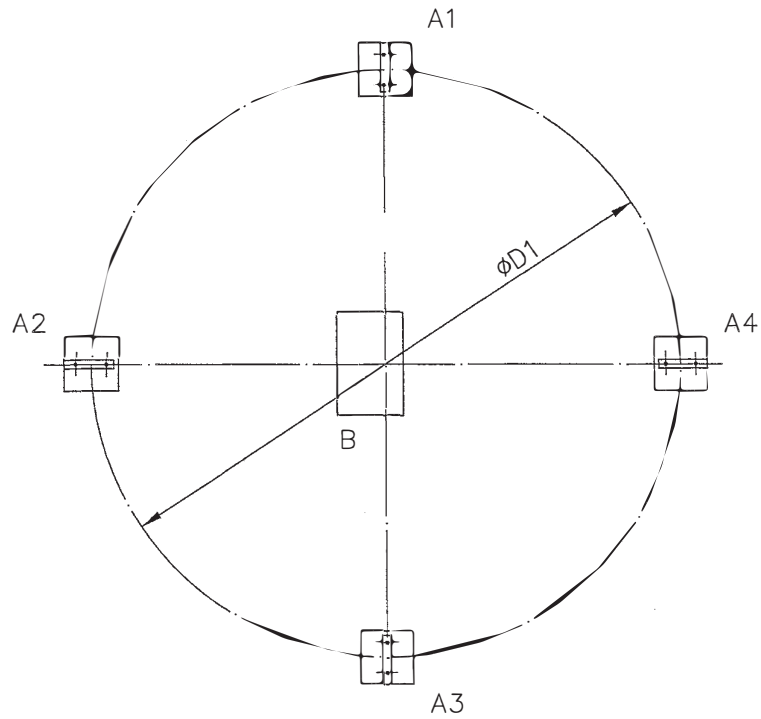

TOWER MODEL T-2	ϕD	LIVE LOAD		DEAD LOAD	
		A1=...=A4	B	A1=...=A4	B
150	112 5/8"	142lb	807lb	738lb	3230lb
175	112 5/8"	162lb	921lb	763lb	3327lb
200	132"	198lb	1124lb	893lb	4800lb
225	132"	219lb	1240lb	925lb	4869lb)
250	132"	235lb	1331lb	953lb	4912lb
300	(156 1/8")	292lb	1658lb	957lb	5385lb
350	(169 1/8")	310lb)	1760lb	1031lb	5840lb

			NOTE		
TITLE	T-2150~2350		CTS		
	DESIGN LIVE LOAD AND DEAD LOAD ON FOUNDATION BASE				
	<i>Lee</i>		MM	/	'20·08 25
			