



MODEL T-270 TOWER SPECIFICATIONS





Cooling Tower Systems, Inc.

TOWER SPECIFICATIONS: MODEL T-270

Design and Operating Conditions		Water Distribution System Construction Materials	
Tower Type:	Counter Flow Induced Draft	Stand Pipe:	PVC
Water Flow Rate (GPM):	206 GPM	Sprinkler Head:	AC
Entering Water Temperature	95°F	Sprinkler Pipes:	PVC
Leaving Water Temperature	85°F	Mechanical Equipment	
Wet Bulb Temperature:	75°F	Fan Unit:	One Unit per Tower
Total Fan BHP:	1.5 HP	Type:	Axial Flow
Total Pump Head:	6.6'	Manufacturer:	CTS
Drift Loss of Water Flow:	0.1%	Diameter:	46 1/16"
Evaporation Loss of Water Flow:	0.93%	Blade Material:	AC
Design Wind Load:	41 lbs/sq. ft.	Hub Material:	AC
Structural Details		Nominal Air Volume:	17,500 CFM
Overall Diameter:	85 5/8"	Fan Motor	
Overall Height:	79 3/8"	Number of motors:	One Unit per Tower
Dry Weight:	610 lbs.	Type:	Induction
Operating Weight:	2,268 lbs.	Manufacturer:	CTS
Basic Tower Construction Materials		Insulation:	F Class
Tower Support Frame Assembly	-	Rated HP:	1.5 HP
Casing:	FRP	Voltage and phase:	220/440V/3
Casing Supporters	HDGS	Piping Connections	
Cold Water Basin	FRP	Primary Water Inlet Diameter	4"
Filling:	PVC	Primary Water Outlet Diameter:	4"
Filling Supports:	HDGS	Auto fill inlet diameter:	3/4"
Fan Guard	HDGS	Quick fill inlet diameter:	-
Mechanical Equipment Supports:	HDGS	Overflow outlet diameter:	1"
Inlet Louvers:	PVC	Drain diameter:	1"
Bolts, Nuts & Washers:	STS	Water Flow (GPM):	206 GPM
Materials Key			
FRP	Fiberglass Reinforced Polyester	STS	Stainless Steel
HDGS	Hot Dipped Galvanized Steel	AC	Aluminum Alloy Cast

Cooling Tower Systems, Inc.

196 Lower Cherry Street Macon, GA 31201

TF: 800.752.1905

F: 478.755.8304

www.coolingtowersystems.com

info@coolingtowersystems.com



Cooling Tower Systems, Inc.

PARTS LIST: MODEL T-270

FOR ASSEMBLY DIAGRAM			FOR TECHNICAL DIAGRAMS			
Ref. No.	Description	QTY	Item No.	Description	Material	QTY
02-01	Water Sump	1	1	Fan Motor	-	1 pcs
02-02	Outlet Nozzle	1	2	V-Belt Reducer	-	-
02-03	Inlet Nozzle	1	3	Motor Frame Assembly	HDGS	1 set
02-04	Over Flow Nozzle	1	4	Fan Blade Assembly	AC	1 set
02-05	Drain Nozzle	1	5	Fan Guard	HDGS	1 set
02-06	Automatic Filler Nozzle	1	6	Casing	FRP	6 pcs
02-08	Float Valve Assembly	1	7	Hand Hole	EVA	1 pcs
02-09	Over Flow	1	8	Sprinkler Head	Nylon	1 set
02-10	Suction Strainer	1	9	Sprinkler Pipes	PVC	4 pcs
02-12A	Connector	1	10	Eliminator	PVC	4 pcs
02-16	Elbow	1	11	Tension Device	-	-
02-19	Inlet Pipe	1	12	Stand Pipe	PVC	1 set
03-01	Water Basin	5	13	Filling	PVC	1 set
04-00	Casing Supporter	6	14	Stopper or Column	AC	1 set
05-01A	Casing	4	15	Filling Supporter	HDGS	1 set
05-06	Hand Hole Cover	1	16	Casing Supporter	HDGS	6 pcs
06-01	Stand Pipe	1	17	Inlet Louver	PVC	1 set
06-04	Stand Pipe Base	1	18	Frame Assembly	-	-
07-01	Stopper	1	19	Water Basin	FRP	5 pcs
07-02	Column	-	20	Water Sump	FRP	1 pcs
08-01	Filling Supporter - A	6	21	Ladder	HDGS	1 set
08-02	Filling Supporter - B	6	22	Strainer	PE	1 pcs
08-03	Filling Supporter - C	6	23	Flange	HDGS	2 pcs
08-04	Fill Supt. Clamping Band	12	24	Basin Supporter	-	-
10-01	Ladder (A Section)	1				
10-02	Ladder (B Section)	1				
10-03	Ladder Bracket - A	2				
10-04	Ladder Bracket - B	2				
11-02	Filling 1/2 Section	4				
11-03	Filling 1-3 Section	-				
12-01	Sprinkler Head	1				
12-02	Center Post	1				
12-03	Turnbuckle	4				
12-04	Tension Wire	4				
13-01	Sprinkler Pipe	4				
13-02	End Cap	4				
13-03	Eliminator	4				
14-00	Motor Frame Assembly	4				
16-01	Fan Motor	1				
16-03	Fan Key	1				
16-04	Fasten Nut	1				
17-01	Fan Hub	1				
17-02	Fan Blade	1				
17-04	U-Bolt	4				
18-01	Fan Guard	8				
20-02	Inlet Louver	2				
20-01-A	Louver Supporter	8				
20-01-B	Down Plug	8				
20-01-C	Up Plug	8				
20-08	Wing Bolt	16				
20-09	Plastic Washer	16				
OTHERS	Bolts & Nuts	1 SET				

Materials Key	
FRP	Fiberglass Reinforced Polyester
HDGS	Hot Dipped Galvanized Steel
STS	Stainless Steel
AC	Aluminum Alloy Cast

Water Basin Sealing Material	
Fiberglass	1 Set—A
Polyester Resin	1 Keg—B
Catalyst	1 Bottle—C

Cooling Tower Systems, Inc.

196 Lower Cherry Street Macon, GA 31201

TF: 800.752.1905

F: 478.755.8304

www.coolingtowersystems.com

info@coolingtowersystems.com



Cooling Tower Systems, Inc.

ASSEMBLY DIAGRAM: MODEL T-270

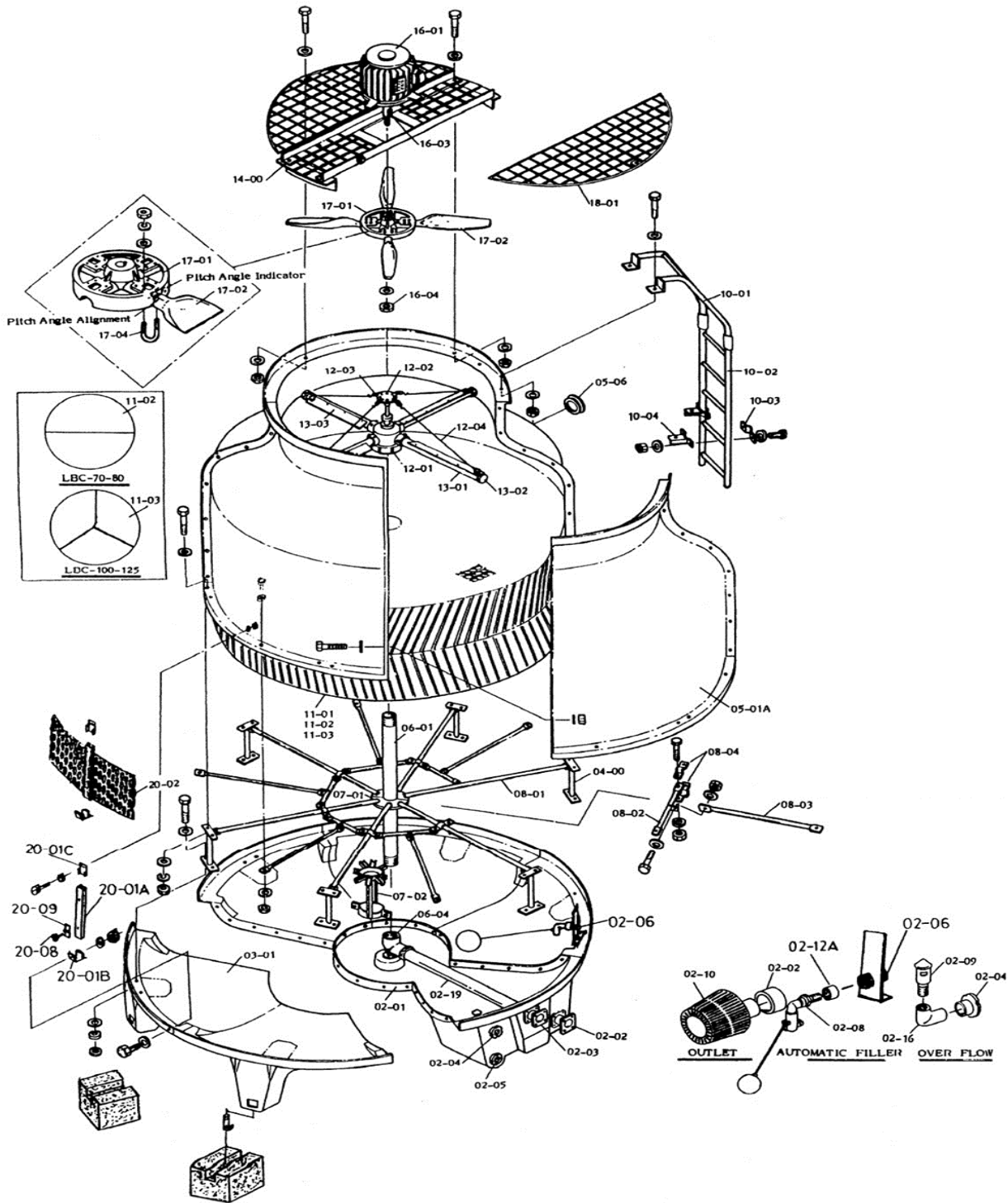

Cooling Tower Systems, Inc.

196 Lower Cherry Street Macon, GA 31201

TF: 800.752.1905

F: 478.755.8304

www.coolingtowersystems.com

info@coolingtowersystems.com

TECHNICAL IMAGE A: MODEL T-270

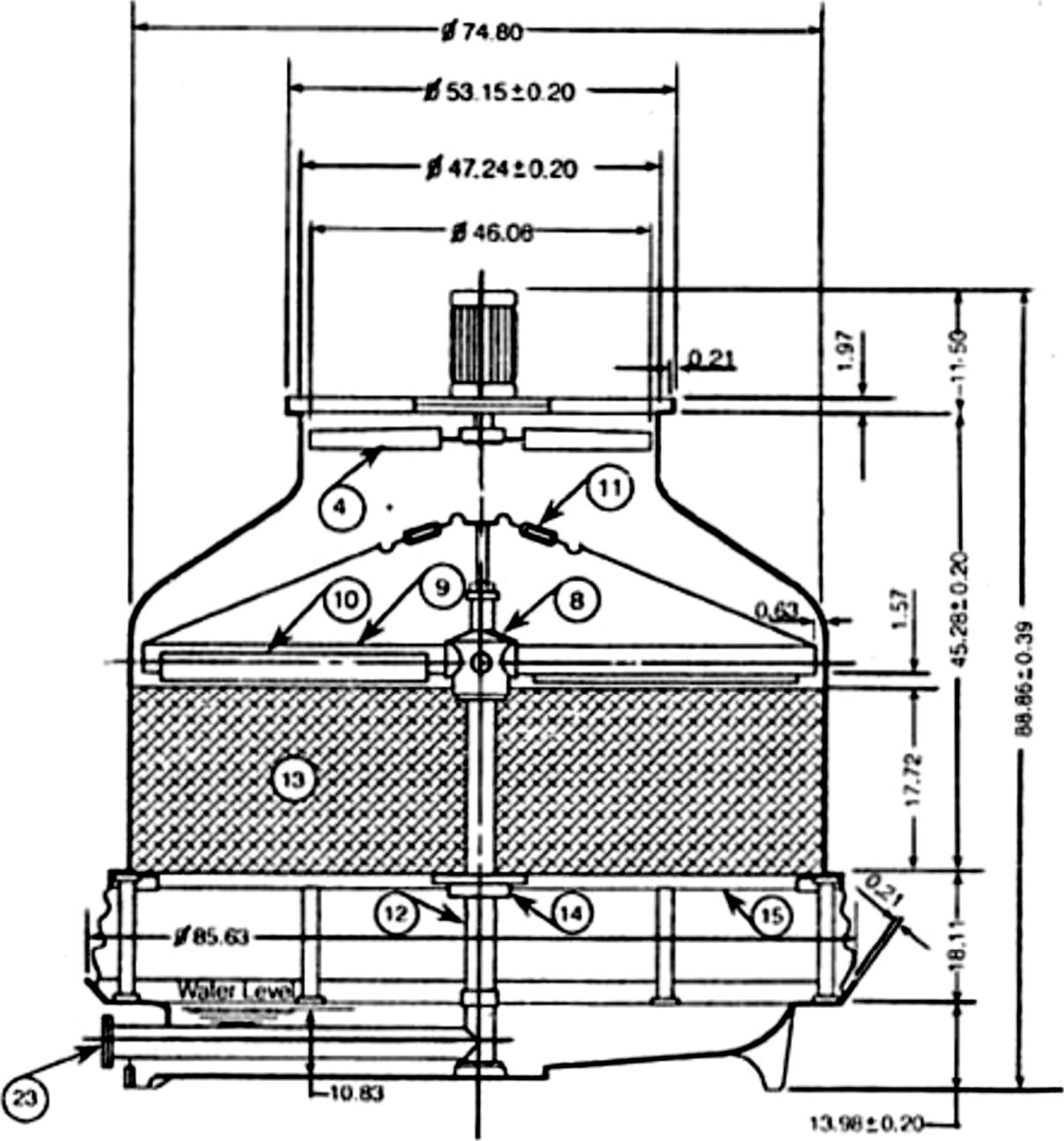

Cooling Tower Systems, Inc.

196 Lower Cherry Street Macon, GA 31201

TF: 800.752.1905

F: 478.755.8304

www.coolingtowersystems.com

info@coolingtowersystems.com



TECHNICAL IMAGE B & C: MODEL T-270 Cooling Tower Systems, Inc.

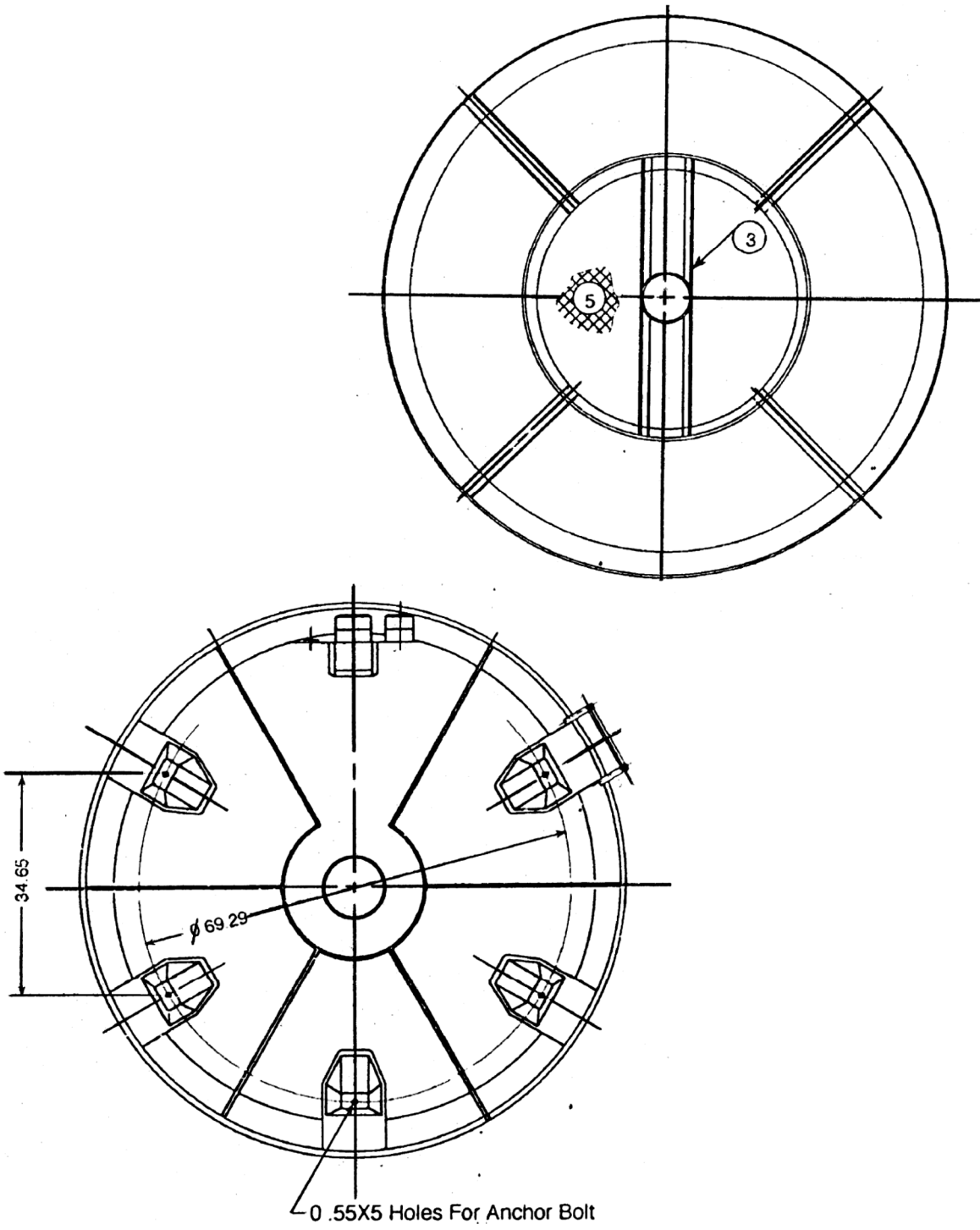



FOUNDATION DRAWING: MODEL T-270 Cooling Tower Systems, Inc.

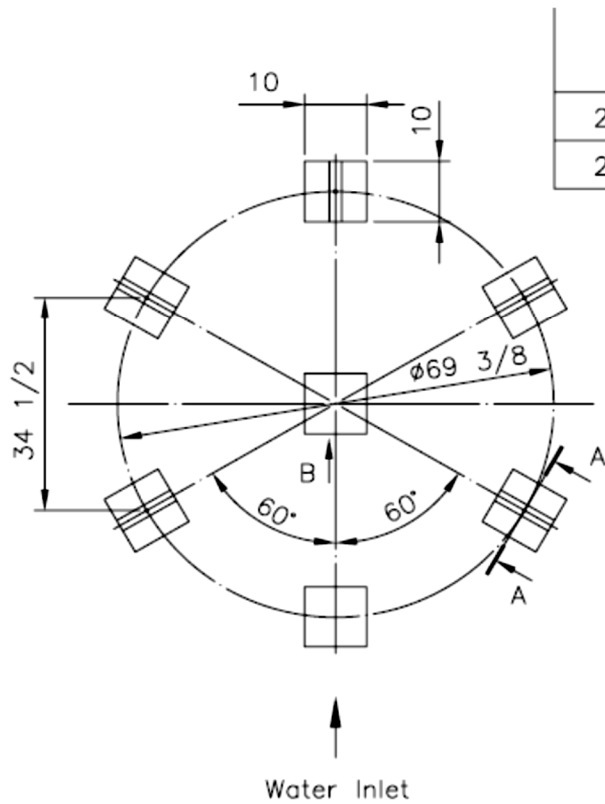

T-	L TYPE ANCHOR BOLT		
	SIZE	L	PCS
270	W 1/2	5	5
280	W 1/2	5	5

On all tower models T-270 and above, please pay close attention to recommended support foundation for center of cooling tower and outward area where inlet/outlet fittings of cooling tower exist

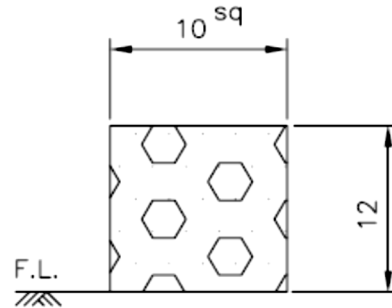

B VIEW

1 1/4" ALL THREAD PROJECTION
W 1/2 X 5L TYPE ANCHOR BOLT 5 PCS

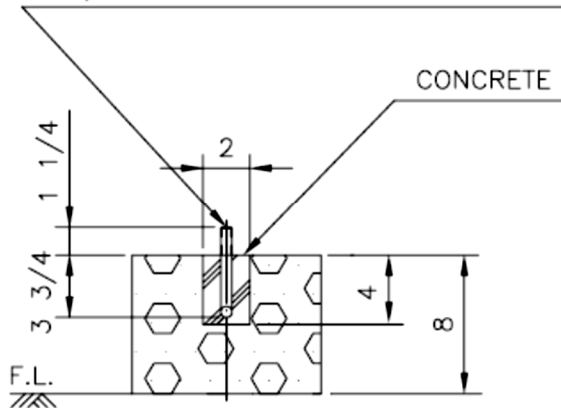

A-A SECTION

Cooling Tower Systems, Inc.

196 Lower Cherry Street Macon, GA 31201

TF: 800.752.1905

F: 478.755.8304

www.coolingtowersystems.com

info@coolingtowersystems.com